

### SUGARING MACHINE

Belshaw's Sugaring Machine is the optimum method for midsize and commissary producers to apply sugar coatings to donuts of any size or variety. Depending on the type of sugar used, the Sugar Machine can process upwards of 350 dozen donuts per hour.

A full screen of donuts can be emptied onto an extra large chute and into the tumbler. The tumbler spins the sugar and donuts, while a spiral rail guides the donuts through the tumbler.

The tumbler is equipped with an automatic nylon hammer to keep sugar from sticking to the tumbler. Finished donuts receive an even sugar coating, while excess sugar is allowed to drop into a container under the open portion of the tumbler for re-use.

Discharge of donuts can be to any type of container, screen or conveyor. Tumblers are removable. Extra tumblers are available for quick changeover of sugar coatings.

Sugaring Machine can be used as an "in-line" unit as well as stand alone. In place of sugar, sprinkles of various types can be used as well.



### Dimensions, Weight

Overall footprint: 84" x 30" (213cm x 76cm)  
Shipping weight: Approx. 450 lbs (205 kg)

### Electrical Specs

120V-60-1, 0.8A or 240V-50/60-1, 0.4A

### Certifications

120V: ETL-certified to NSF-2 and UL-789  
240V: ETL-certified to NSF-2

### Accessories

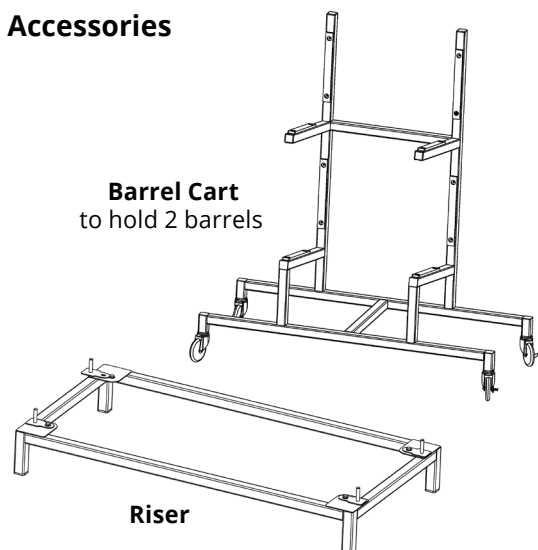

to lift height of unit 6in (15.25cm)

