

HG18 & HG24 Donut Glazers

Belshaw's HG glazers allow fast, uniform glazing of donuts, cinnamon rolls and other. These glazers conveniently glaze one full screen at a time with minimal waste.

Glazers are on casters and require little space. A bottom shelf provides storage space for screens and a glaze bucket. A drain valve allows left over glaze to be drained back into a glaze bucket. Stainless steel construction and sound design facilitate cleaning and provide a durable product that will stand up to years of everyday use.

The EZlift method employed by the glazer eliminates the lifting associated with standard hand glazers. Rather than being carried by the operator, the glaze applicator slides along rails, and tilts down to fill up with glaze. This design provides glaze coverage with little strain on the operator.

STANDARD ITEM NUMBERS

- HG18C Item # 22526
- HG18EZ Item # 22529
- HG24C Item # 22534
- HG24EZ Item # 22536

STANDARD FEATURES

- **HG18C** glazes a 17" x 25" screen of donuts
- **HG18C** glaze applicator is a clamshell opening design to control flow of glaze. Operator lifts the glaze applicator manually.
- **HG18EZ** glaze applicator slides on rails. Operator tilts frame to fill glaze applicator.
- **HG24C** glazes a 24" x 24" screen of donuts
- **HG24EZ** glaze applicator slides on rails. Operator tilts frame to fill glaze applicator.
- **HG24C** glaze applicator is a clamshell opening design to control flow of glaze. Operator lifts the glaze applicator manually.
- Drain tray is standard on both models
- Drain returns unused glaze to a bucket for later use.
- Stainless steel construction throughout.
- 4" heavy duty casters (2 lockable).
- Washable in rack washer or by hose down and brush.
- Covers sold separately
- Certified to NSF-2.

Cover for HG18-1505

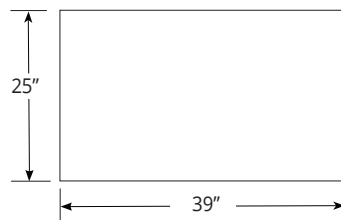
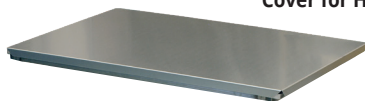

CERTIFICATIONS



HG18C Donut Glazer
(screens supplied separately)



HG18EZ Donut Glazer
(screens supplied separately)



HG24C Donut Glazer
(screens supplied separately)



HG24EZ Donut Glazer
(screens supplied separately)

HG18 DIMENSIONS & SHIPPING DATA

HG18C GLAZER HAS SAME DIMENSIONS, EXCEPT 34" (86 CM) HEIGHT

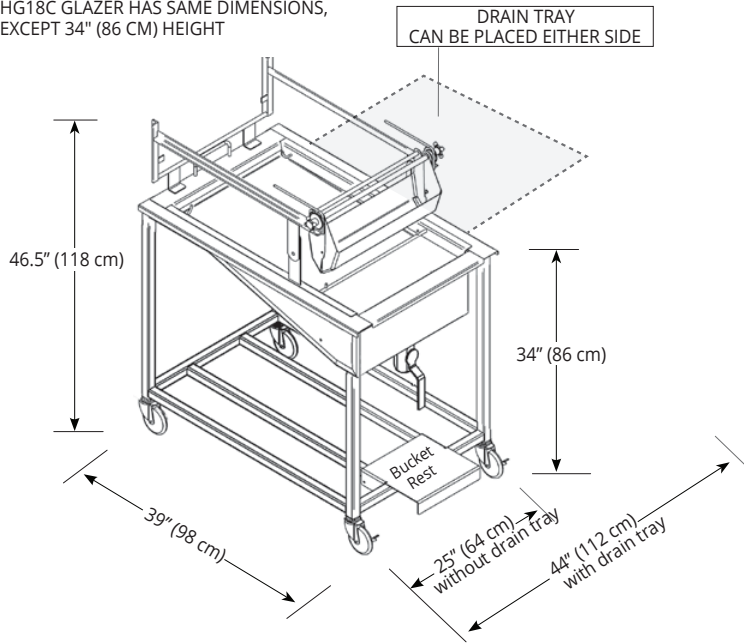

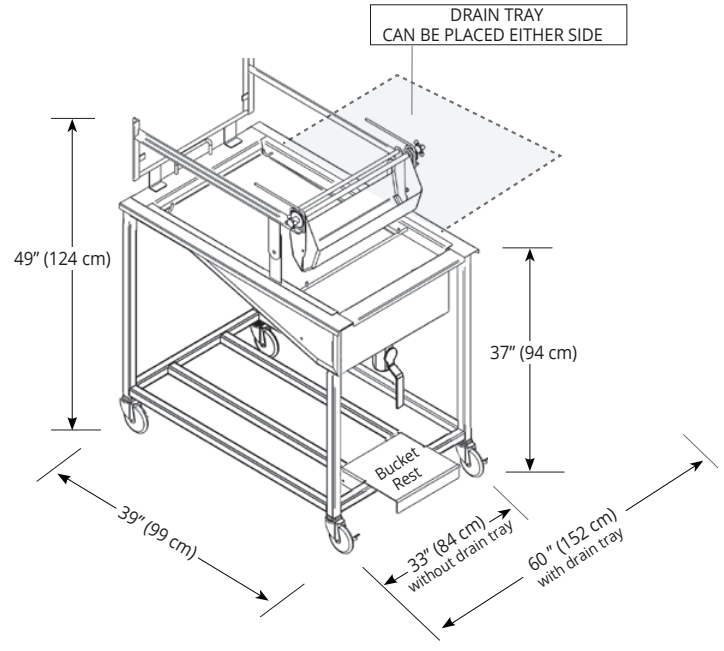

HG24 DIMENSIONS & SHIPPING DATA



DIMENSIONS		HG24C Manual	HG24EZ EZLift	HG18EZ	HG18C
OVERALL DIMENSIONS 1 drain tray down	inches	33" W x 39" D x 37" H	33" W x 39" D x 49" H	25" W x 39" D x 46.5" H	25" W x 39" D x 34" H
	cm	84 x 99 x 94 cm	84 x 99 x 124 cm	64 x 98 x 118 cm	64 x 98 x 86 cm
OVERALL DIMENSIONS 2 drain tray extended	inches	60" W x 39" D x 37" H	60" W x 39" D x 49" H	44" W x 39" D x 46.5" H	44" W x 39" D x 34" H
	cm	152 x 99 x 94 cm	152 x 99 x 124 cm	112 x 98 x 118 cm	112 x 98 x 86 cm
SHIPPING DATA (Approximate, shipped in carton or pallet)	inches	48"W x 40"D x 47"H	48"W x 40"D x 47"H	48" x 40" x 42"	48" x 40" x 42"
	cm	122 x 102 x 119cm	122 x 102 x 119 cm	122 x 102 x 107cm	122 x 102 x 107cm
	lbs	215 lbs	183 lbs	205 lbs	165 lbs
	kg	97 kg	83 kg	93 kg	75 kg

GLAZING SCREENS (Purchased separately)

		GLAZER MODEL	PART NUMBER (for GLAZING SCREENS)	SCREEN SIZE	APPROX. SHIPPING WEIGHT (Carton of 12 screens)
		HG18EZ, HG18C	SL200-0004	17" x 25" (43 x 63 cm)	45 lbs (21 kg)
		HG24C, HG24EZ	HG24-0001	24" x 24" (61 x 61 cm)	54 lbs (23 kg)
HG24-0001 Glazing Screen		FREIGHT CLASS: 70 (Screens only)			
SL200-0004 Glazing Screen					