

Thermoglaze TG50 Frozen Donut System

For retailers who want to produce fresh tasting, high-quality, attractive donuts without the labor and equipment necessary to prepare and fry donuts from scratch, Belshaw's Thermoglaze is the solution. Thermoglaze TG50 is a system that re-heats and glazes pre-fried frozen donuts and other baked goods, with results that rival the quality of freshly made product.

- The Thermoglaze TG50 can process several varieties of thawed from frozen donuts currently available including ring donuts, fritters, long johns, cream and jam-filled donuts and many others. Thermoglaze is easy to operate, can be used in full view of customers, and requires no ventilation hood.
- The Thermoglaze TG50 typically processes approximately 50-75 dozen donuts per hour. Heating time and temperature are adjustable.
- Frozen donuts (or similar product) are first thawed in a proofer. Donuts can be held in a proofer for up to five hours before processing in the TG50.
- After thawing/holding in a proofer, the screens full of donuts are placed on the TG50's conveyor for heating and glazing, which takes less than 5 minutes.
- Glaze is pumped up to a dispenser which coats each donut under a curtain of glaze as they pass through. For iced donuts, the flow of glaze is turned off, and donuts can be iced on a Belshaw H&I-2 or H&I-4 icer.
- The TG50 uses 17 x 25 inch glazing screens, Belshaw Part # SL200-0004. Each screen holds 2 dozen standard donuts. 24 or more screens are recommended.



TG50 (front view)



TG50 (rear view)



TG50 glazer in operation



Filled donuts after glazing on TG50

STANDARD FEATURES

- Simple 2-switch operation (Oven and Glazer)
- Capacity 50-75 dozen donuts/hour
- No ventilation hood or fire suppression system normally required. (Verify with local authorities)
- Heavy duty glaze pump
- Speed and temperature adjustable inside control box
- Glaze pump can be switched on/off as required
- Stainless steel construction
- Easy to clean oven interior
- 2 Teflon handles supplied for picking up screens
- 4" (25mm) casters, locking
- Lock-out feature to prevent machine starting while cleaning is in progress

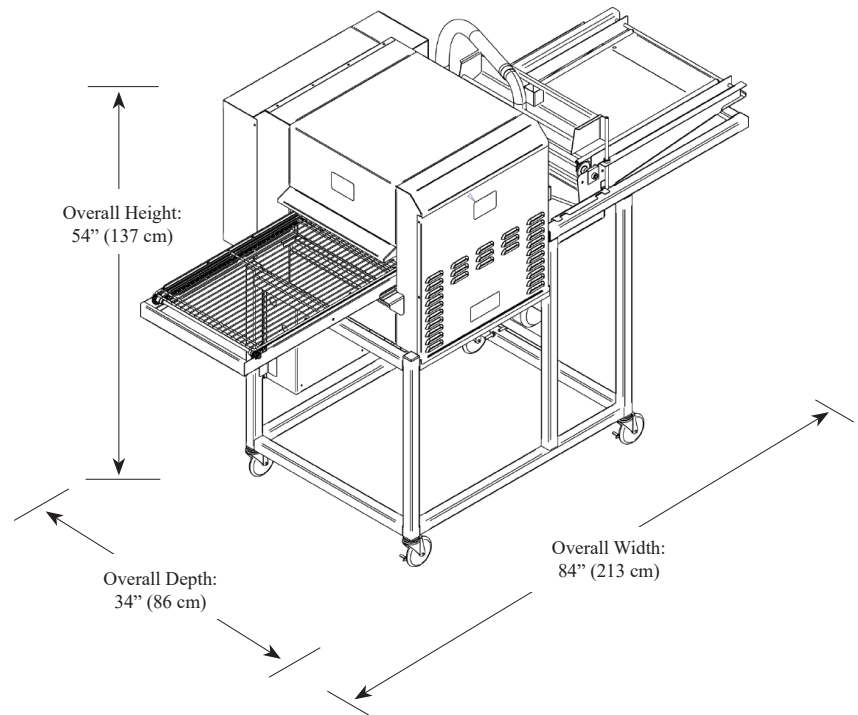

ELECTRICAL DATA

- Volts: 208 Volts, 60 Hertz, 1 phase
- Amps: 32.2A
- Kilowatts: 6.7 KW
- Plug: 360P6W
- Cord: 72" (1.8m)

SHIPPING DATA

- Shipped on pallet
- Width: 66" (168 cm)
- Depth: 42" (107 cm)
- Height: 62" (157 cm)
- Shipping weight: 496 lbs (295 kg)
- Screen weight: 45 lbs (21 kg) per dozen screens

CERTIFICATIONS

- Certified to UL-197, CSA C22.2, NSF-4 and NSF-8
- CE models available



OPTIONAL SUPPORT EQUIPMENT

 <p>H&I-2 Icer: Two 13" bowls</p>	 <p>H&I-4 Icer: Four 13" bowls</p>	 <p>Extra screens (17" x 25") SL200-0004</p>	 <p>CP Proofer</p>
--	---	---	--