

BABG-10 Countertop Mixer

10-quart capacity

Item#21697

STANDARD FEATURES

- Five-speed direct drive transmission
- Digital control panel
- Speed shifts permitted while unit is running
- Compact and light weight design for small footprint, easier cleaning, and portability
- Non-skid rubber base • Includes:
 - Dough hook
 - Wire whip
 - Flat beater
- Stainless steel mixing bowl
- Commercial grade table model
- Safety guard
- Extra bowls available (Item # 966-0010-1)



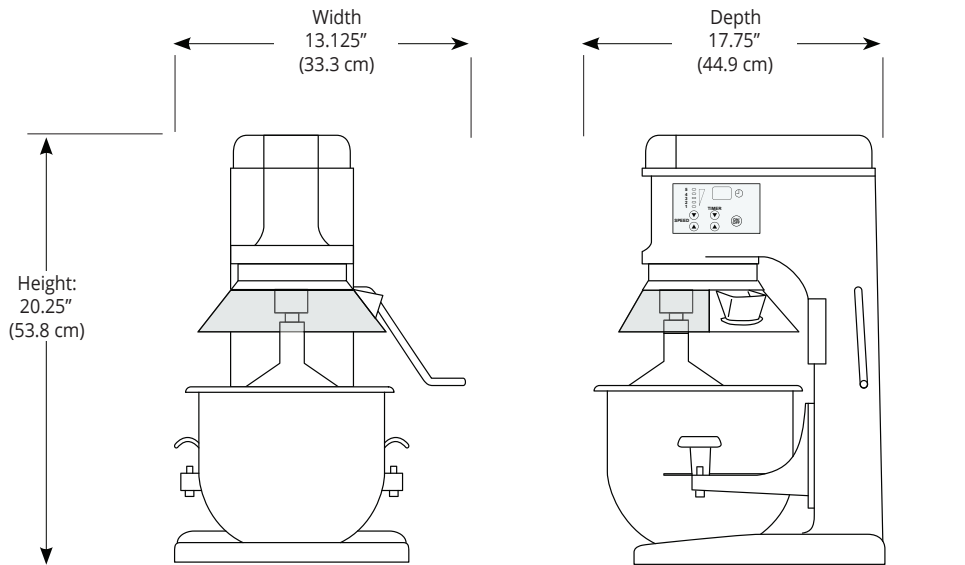

CONTROL PANEL

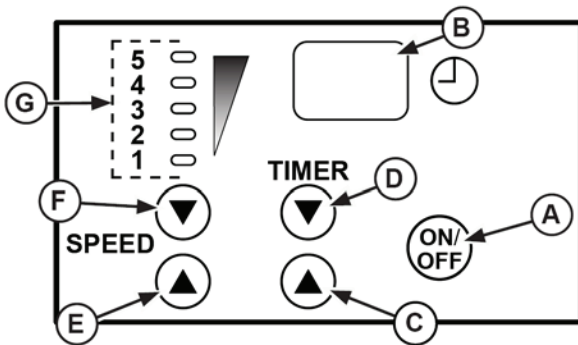

(A) ON/OFF BUTTON

(B) DIGITAL DISPLAY

- Displays time remaining when in timed operation cycle
- Displays "ON" when operating in a non-timed mode
- Displays "OFF" when not operating

(C) TIME UP BUTTON

- Increases the time. Maximum time of 30 minutes

(D) TIME DOWN BUTTON

- Decreases the time

(E) SPEED UP BUTTON

(F) SPEED DOWN BUTTON

(G) INDICATOR LIGHTS

- Shows current mixing speed

Dimensions and weight (NET)

- Net Width: 13.125" (33.3 cm)
- Depth: 17.75" (44.9 cm)
- Height: 20.25" (53.8 cm)
- Weight: 47 lbs (21.36 kg)

Shipping Dimensions (GROSS)

- 21"x26"x25" (53x66x64 cm)
- Gross Weight: 54 lbs (25 kg)

Electrical

- Volts: 110V
- Amps: 6A
- HP: 1/3 hp
- Plug: NEMA 5-15P

Certifications

- Certified ETL-C-US, NSF