

## Donut Robot® Auto Fryers - Mark VI

The Donut Robot Mark VI conveyor fryer forms part of Belshaw's Mark VI Production System. It produces consistent quality products with minimal labor and training. The Mark VI system allows for significant donut throughput in a small amount of space.

- **Cake donuts:** The Mark VI system produces top quality cake donuts, using one of 2 methods, which can be chosen at the time of purchase:
  - **Donut Robot dual automatic depositors** – Automatic synchronized drops, for Ring donuts only
  - **Belshaw Type F electric manual depositor** – Manually operated and capable of a full variety of cake donuts, including Crullers, Sticks, Krinkles, and more.
- **Yeast-raised donuts:** The Mark VI produces excellent yeast-raised donuts, using a CP Proofer, and the Mark VI accessory Feed Table, Trays and Cloths. In addition to Ring donuts, the system can produce Berliners ('Bismarcks'), Bars ('Long Johns'), Twists and Fritters.
- **Electronic Heat Controller:** Maintains steady temperature for a consistent product.

### MARK VI MODELS

- **Mark VI Standard with 3¾" conveyor:** For donuts up to 3½ inches (89 mm) width. Flight bars are spaced every 3¾ inches (95 mm). Accepts Long Johns and Twists up to 8 inches in length.
- **Mark VI Standard with 4½" conveyor:** For large donuts up to 4 inches (102 mm) width. Flight bars are spaced every 4½ inches (114 mm). Accepts Long Johns and Twists up to 8 inches in length.



Donut Robot® Mark VI Standard (3¾ inch conveyor shown)



Mark VI Standard with Type F Depositor



Mark VI with Dual Automatic depositors

### PRODUCTION CAPACITY

@120-second frying time	Conveyor spacing	Donuts per hour (estimated)
Mark VI	3¾" (95 mm)	88 dozen (1056 pieces)
Mark VI	4½" (114 mm)	72 dozen (864 pieces)

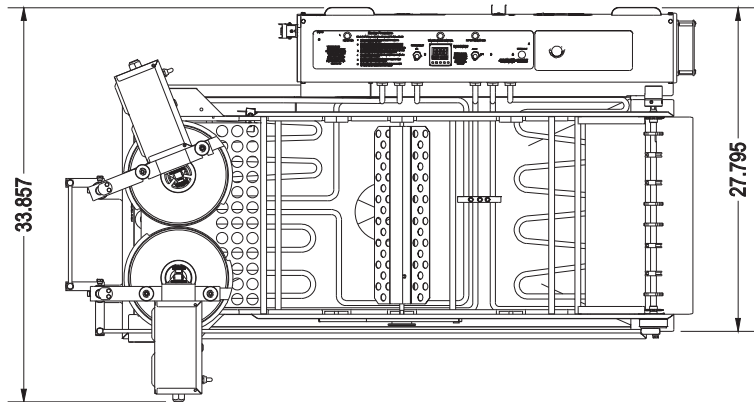
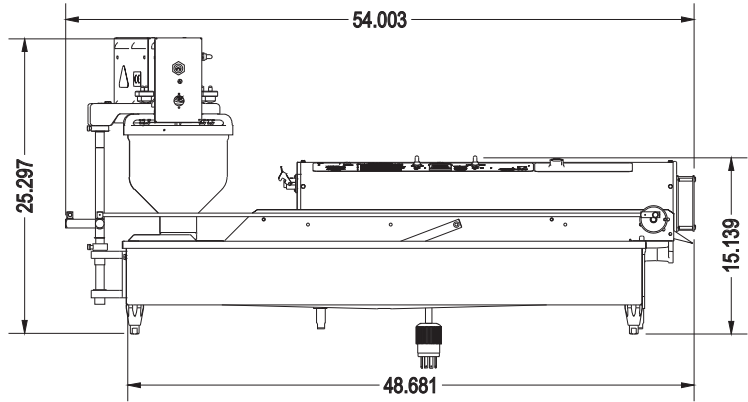
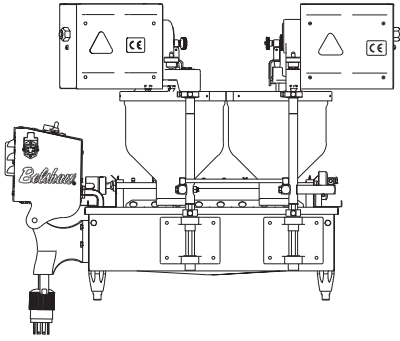

#### MARK VI FRYER FEATURES

- Stainless steel kettle construction.
- Stainless steel conveyor with flight bar system for advancing donuts.
- Automatic turning and dispensing of donuts.
- Holds 4 donuts per flight bar pocket.
- Mark VI Standard: conveyor may be chosen with flight bars spaced 3¾ inches (95mm) or 4½" (114 mm), from center-to-center.

- Adjustable frying times from approximately 65 to 360 seconds.
- High-accuracy electronic temperature controller.
- High durability, low watt-density heating elements.
- High temperature safety limit switch.

#### MARK VI FRYER OPTIONS

- Extended drain with valve (Item# MK-0546). The drain extends below the fryer and requires a hole in the fryer's supporting table.

- Dual Automatic Depositing system (or Type F Depositor)

#### VENTILATION AND FIRE SUPPRESSION

- Customer is responsible for installation of ventilation hood and/or fire suppression as required by local codes.

#### CERTIFICATIONS

- Certified to UL-197, CSA C22.2, NSF-169.
- CE models available.



#### CLEARANCE

- 2 inches (5 cm) between machine and all construction.

#### MARK VI FRYER SPECIFICATIONS

#### MARK VI Standard

FRYING WIDTH	16 inches
	406 mm
FRYING DEPTH	4.5 inches
	114 mm
SHORTENING CAPACITY (by weight, approximate)	124 lbs
	57 kg
SHORTENING CAPACITY (by volume, approximate)	17 gal
	63 L
<b>ELECTRICAL DATA</b>	(Other voltages available)
@ 208-220V, 50/60hz, 3ph	32.5 A - 37.2 Amps
	11.5 - 15.3 Kilowatts
PLUG	NEMA 15-50P (US/Canada) <sup>1</sup>
CORD	6 feet (1.83 m)
SHIPPING DIMENSIONS <sup>2</sup> (estimated)	56 x 34 x 20 inches
	142 x 86 x 51 cm
SHIPPING WEIGHT <sup>2</sup> (estimated)	190 lbs
	86 kg
Outside US/Canada/Mexico, plug to be supplied by customer. Equipment may be crated or cartoned.	