

Donut Robot® Auto Fryers (Gas)

Belshaw Automatic's Donut Robot® Mark II Gas / Mark II GP Gas Fryers deposit, fry, turn, and dispense cake donuts and mini donuts automatically. These fryers use the same cake donut depositor and the same conveyor as Donut Robot® electric models and produce donuts of the same high quality. Training and labor requirements are low, while consistent donuts are produced by a single person.

- Donut size can be adjusted to make smaller or larger donuts. (approx 20%)
- Frying time and temperature can be adjusted through a wide range.
- Donut Robot® fryers can reduce oil absorption in comparison with most kettle fryers applications.

MODEL SELECTION

- Standard size donuts: Donut Robot® Mark II Gas
- Standard size and mini donuts: Donut Robot Mark II Gas with Mini Donut Hopper/Plunger Kit, Item #MK-1502-1
- Only mini donuts at increased throughput: Donut Robot® Mark II GP Gas

ACCESSORIES

- Filter-Flo Siphon (Item #DR42-1048). Durable large siphon with heat resistant handle and cone filter, for filtering shortening.
- Roto-Cooler (Item #22104). Revolving white polyethylene tray for collecting donuts as they are dispensed from fryer.
- Shortening Reserve Tank (Item #MKV-1012) Small s/s container for holding shortening above the fryer, with valve for refilling fryer.
- FT42 Feed Table with trays/cloths for yeast raised donuts.



Donut Robot® Mark II Gas with Donuts



Donut Robot® Mark II Gas with Mini Donuts



Donut Robot® Mark ii GP Gas (mini donuts only)

CAPACITY Estimated	Standard Rings @120 sec fry times	Mini Donuts @90 sec fry time
Mark II GP Gas		102 dozen/hour (1224 pcs)
Mark II Gas	30 dozen/hour (360 pcs)	
Mark II Gas (with Mini Donut Kit)	30 dozen/hour (360 pcs)	79 dozen/hour (948 pcs)

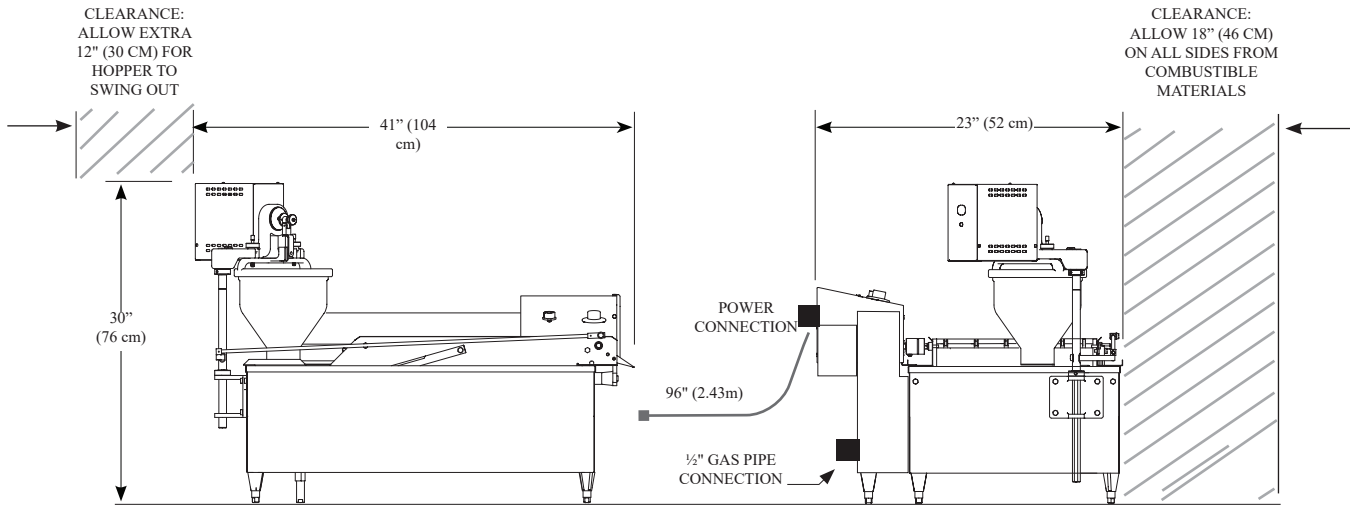

STANDARD FEATURES

- Automatic cake donut depositor, synchronized with fryer conveyor.
- Mark II Gas: 'Plain' donut plunger, 1-9/16" (40mm) diameter. Deposits 2 standard size donuts per conveyor row.
- Mark II GP Gas: double 1" (25.4mm) diameter plunger. Deposits 4 mini donuts per conveyor row.
- Stainless steel conveyor with flight bar system for advancing donuts.
- Mark II Gas: the conveyor's flight bars are spaced 3¾" (95mm) from center to center.
- Mark II GP Gas: the conveyor's flight bars are spaced 3" (76mm) from center-to-center for mini donuts.
- Aluminum hopper with 10 lbs (4.5kg) batter capacity.
- Batter weight adjustment dial allows variation in donut size.
- Automatic turning of donuts mechanically synchronized with fryer.
- Automatic dispensing of fried donuts onto collection device such as Roto-Cooler.
- Frying time dial sets wide range of frying times.
- Temperature adjustment (thermostat).
- High temperature limit switch
- Half-speed switch that reduces automatic cake donut deposits to 1 donut per conveyor row instead of 2. For GP models, 2 per row instead of 4 for times of reduced demand.
- Does not have a drain; use optional accessory Filter-Flo Siphon.

OPTIONS

- For Mark II Gas: 1-9/16" Star Plunger. Makes ring donuts with a star shape around the center hole.
- Mini donut conversion kit (Item#MK-1502-1). This kit includes mini donut hopper and double plunger, for depositing 4 mini donuts per conveyor row (as used on GP model). Changeover from standard to mini donuts and back again takes less than one minute.

CERTIFICATIONS

- Safety ANSI 283.11, CSA 1.8, Sanitation NSF 169



VENTILATION AND FIRE SUPPRESSION

- Customer is responsible for ventilation hood and fire suppression required by local codes.

ELECTRICAL DATA

- 120 V, 50/60 Hz, 1 ph, 0.36 kW, 3 A
 - 208/240 V, 50/60 Hz, 1 ph, 0.40 kW, 1.8 A
- (Electrical supply is necessary to power the conveyor and depositor)

GAS DATA

- Gas connection: 1/2" NPT (Female); Capacity: 35,000 BTU/hr
- Pressure requirement:
 - Propane Gas @ 11-14 inches W.C.

CLEARANCE

- 18 inches (46 cm) to any combustible material
- 2 inches (5 cm) between machine and all construction
- 12 inches (30 cm) at infeed for depositor to swing out
- 24 inches (61 cm) at outfeed for Roto-Cooler or other receptacle

FRYING AREA AND SHORTENING CAPACITY

- Frying area: 32"L x 12"W x 4"D (81 x 30.5 x 10 cm)
- Shortening volume: 6.6 gallons (25.2 liter)
- Shortening weight: 49.4 lbs (22.5 kg)

SHIPPING DATA

- Fryer carton: 56"x40"x31", 226 lbs (142x102x79cm, 103 kg)
- Depositor carton: 16"x16"x22", 24 lbs (41x41x56cm, 11 kg)