



TSPI 80-200



Self-tipping spiral mixer

TSPI is a compact self-tipping mixer, consisting of a SPI spiral mixer permanently coupled with a hydraulic lifter, designed to lift up the entire machine body vertically and, through a rotation, to tip the dough in the bowl onto the underlying worktable or onto the special volumetric divider hopper, on the right- or the left-hand side, according to the type of model chosen. TSPI combines consequently the features of functionality, modernity, ergonomics and high performance of SPI mixers with the effectiveness of a reliable and safe lifting and tipping system, which, even within narrow spaces, allows the kneaded dough to be moved to the next working process without physical efforts for the operator.

Standard features

- Shockproof thermoformed ABS head cover.
- Manual or automatic selection and monitoring of working cycle through a membrane keyboard panel in the electronic version. Storage of up to 9 recipes.
- High-resistant stainless steel bowl, spiral arm and dividing blade.
- Transparent plastic bowl lid suitable for food contact in compliance with the strictest hygienic and safety regulations.
- Electric panel housed in an IP55 protection box.
- Rigid and torsional stress-resistant single-body structure and outer paneling coated with epoxy powder.
- Access to facilitate inspection and routine maintenance.
- Hydraulic lifting and tipping system.
- Column positioned upwards or downwards on the right- or the left-hand side, depending on the tipping requirements.
- Lifter control device with two-hand and "hold-to run" push-button panel including:
 - up and down driving buttons
 - driving buttons for bowl rotation during tipping (version from the bottom)
 - driving buttons for bowl and spiral arm rotation (version from the top).

Accessories-optional

The machine is available in electronic version only and can be supplied with the following accessories:

- Lid + grid: stainless steel grid in addition to the transparent lid;
- Dough temperature detector with infrared sensor, visualization on display and stop option of the working process. Stainless steel slide

Configurations

TIPPING HIGH, ON HOPPER

- TSPI HR - right-hand side tipping
- TSPI HL - left-hand tipping



TSPI - Tipping onto hopper



TSPI - Tipping onto worktable

TIPPING LOW, ONTO A WORKTABLE

- TSPI HR - right-hand side tipping
- TSPI HL - left-hand side tipping

SPECIAL EXECUTIONS UPON REQUEST
Customized executions, i.e. different tipping heights or versions with automatic tipping and whole protection case (industrial version) are available upon request, i.e. as per customer's specifications.

Electronic control panel



Lifter control panel



**MODELS - Tipping onto worktable**

TSPI 80 BR	Spiral mixer with approx. kg. 80 dough capacity (approx kg.50-54 flour capacity) Bowl diameter: 700 mm. Right-hand side tipping onto worktable
TSPI 80 BL	Spiral mixer with approx. kg. 80 dough capacity (approx kg.50-54 flour capacity) Bowl diameter: 700 mm. Left-hand side tipping onto worktable
TSPI 100 BR	Spiral mixer with approx. kg. 100 dough capacity (approx kg.62-65 flour capacity) Bowl diameter: 700 mm. Right-hand side tipping onto worktable
TSPI 100 BL	Spiral mixer with approx. kg. 100 dough capacity (approx kg.62-65 flour capacity) Bowl diameter: 700 mm. Left-hand side tipping onto worktable
TSPI 130 BR	Spiral mixer with approx. kg. 130 dough capacity (approx kg.75-80 flour capacity) Bowl diameter: 800 mm. Right-hand side tipping onto worktable
TSPI 130 BL	Spiral mixer with approx. kg. 130 dough capacity (approx kg.75-80 flour capacity) Bowl diameter: 800 mm. Left-hand side tipping onto worktable
TSPI 160 BR	Spiral mixer with approx. kg. 160 dough capacity (approx kg.100 flour capacity). Bowl diameter: 900 mm. Right-hand side tipping onto worktable
TSPI 160 BL	Spiral mixer with approx. kg. 160 dough capacity (approx kg.100 flour capacity). Bowl diameter: 900 mm. Left-hand side tipping onto worktable
TSPI 200 BR	Spiral mixer with approx. kg. 200 dough capacity (approx kg.125 flour capacity). Bowl diameter: 900 mm. Right-hand side tipping onto worktable
TSPI 200 BL	Spiral mixer with approx. kg. 200 dough capacity (approx kg.125 flour capacity). Bowl diameter: 900 mm. Left-hand side tipping onto worktable

MODELS - Tipping onto hopper

TSPI 130 HR	Spiral mixer with approx. kg. 130 dough capacity (approx kg.75-80 flour capacity) Bowl diameter: 800 mm. Right-hand side tipping onto hopper
TSPI 130 HL	Spiral mixer with approx. kg. 130 dough capacity (approx kg.75-80 flour capacity) Bowl diameter: 800 mm. Left-hand side tipping onto hopper
TSPI 160 HR	Spiral mixer with approx. kg. 160 dough capacity (approx kg.100 flour capacity) Bowl diameter: 900 mm. Right-hand side tipping onto hopper
TSPI 160 HL	Spiral mixer with approx. kg. 160 dough capacity (approx kg.100 flour capacity) Bowl diameter: 900 mm. Left-hand side tipping onto hopper
TSPI 200 HR	Spiral mixer with approx. kg. 200 dough capacity (approx kg.125 flour capacity) Bowl diameter: 900 mm. Right-hand side tipping onto hopper
TSPI 200 HL	Spiral mixer with approx. kg. 200 dough capacity (approx kg.125 flour capacity) Bowl diameter: 900 mm. Left-hand side tipping onto hopper

ACCESSORI - OPTION

	Lid + grid: stainless steel grid in addition to the transparent lid.
	Dough temperature detector with infrared sensor, visualization on display and stop option of the working process
	Slide: according to the required discharge heights



IMPASTATRICE AUTOMATICA ROVESCIBILE TSPI 80-200

NOR13A002_01

AUTOMATIC SPIRAL MIXER WITH TIPPING DEVICE TSPI 80-200

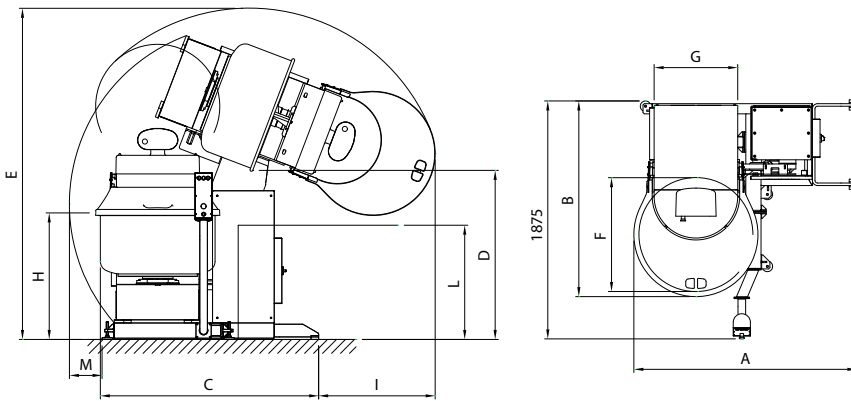
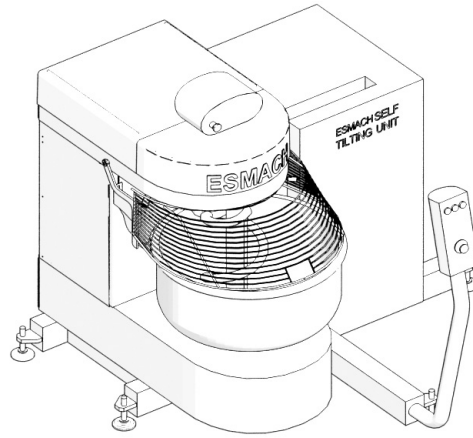

ABBINAMENTI
TYPES OF COUPLING

TSPI BL

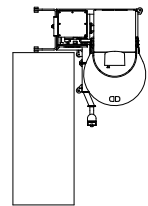
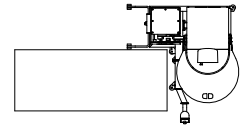

TSPI BR

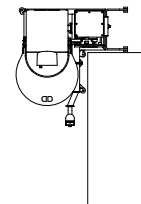
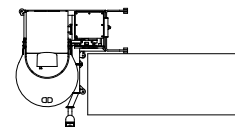

IMPASTATRICE AUTOMATICA ROVESCIBILE / AUTOMATIC SPIRAL MIXER WITH TIPPING DEVICE

DATI TECNICI / TECHNICAL FEATURES	TSPI	80 BR 80 BL	100 BR 100 BL	130 BR 130 BL	160 BR 160 BL	200 BR 200 BL
A	mm	1605	1605	1706	1706	1706
B	mm	1333	1333	1458	1542	1542
C	mm	1560	1560	1670	1720	1720
D	mm	1410	1410	1410	1360	1340
E	mm	2378	2378	2540	2610	2610
F (DIAMETRO INTERNO / INNER DIAMETER)	mm	700	700	800	900	900
G	mm	560	560	660	660	660
H	mm	950	1000	920	940	1000
I	mm	662	662	825	920	920
L	mm	900	900	900	900	900
M	mm	200	200	300	300	300
POTENZA INSTALLATA / INSTALLED POWER	kW	5,65	5,65	7,9	9,5	9,5
POTENZA MAX ASSORBITA / MAX ABSORBED POWER	kW	4,55	4,55	6,8	8,4	8,4
CONNESSIONE ELETTRICA / PLUG COUPLING		3PH+Gr	3PH+Gr	3PH+Gr	3PH+Gr	3PH+Gr
PESO / WEIGHT	kg	747	747	954	1010	1035



IMPASTATRICE AUTOMATICA ROVESCIBILE TSPI 80-200

NOR13A003_02

AUTOMATIC SPIRAL MIXER WITH TIPPING DEVICE TSPI 80-200

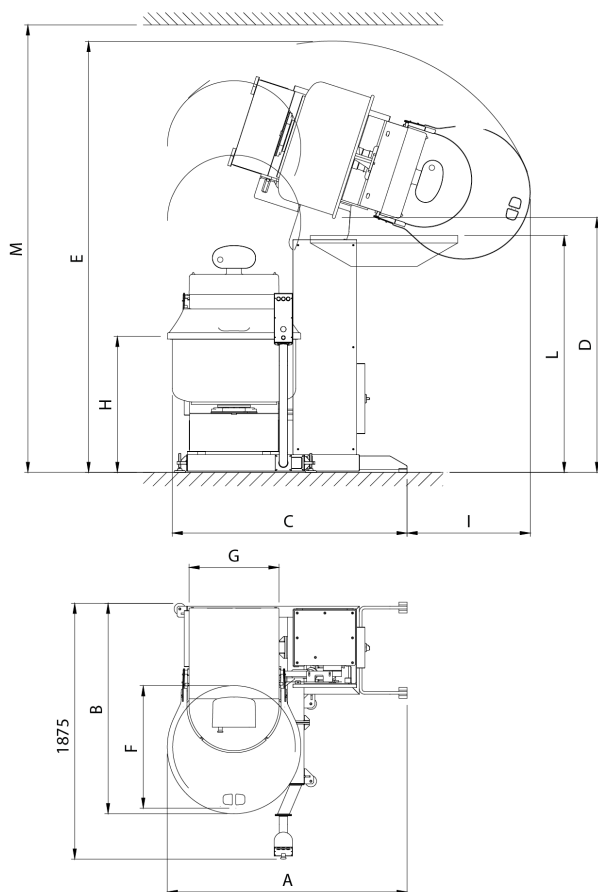

ABBINAMENTI / TYPES OF COUPLING

TSPI HL

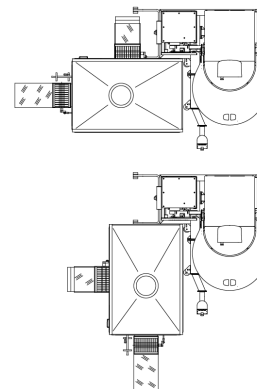

TSPI HR

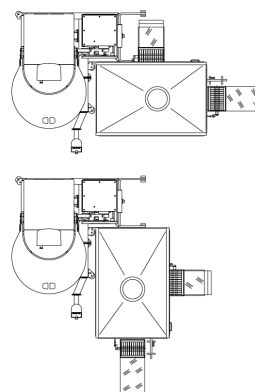

IMPASTATRICE AUTOMATICA ROVESCIBILE / AUTOMATIC SPIRAL MIXER WITH TIPPING DEVICE

DATI TECNICI / TECHNICAL FEATURES	TSPI		130 HR 130 HL	160 HR 160 HL	200 HR 200 HL
A	mm		1706	1706	1706
B	mm		1458	1542	1542
C	mm		1670	1720	1720
D	mm		1960	2000	1880
E	mm		3105	3160	3160
F (DIAMETRO INTERNO / INNER DIAMETER)	mm		800	900	900
G	mm		660	660	660
H	mm		920	940	1000
I	mm		855	910	910
L	mm		1750	1750	1750
M	mm		3205	3260	3260
POTENZA INSTALLATA / INSTALLED POWER	kW		7,9	9,5	9,5
POTENZA MAX ASSORBITA / MAX ABSORBED POWER	kW		6,8	8,4	8,4
CONNESSIONE ELETTRICA / PLUG COUPLING			3PH+Gr	3PH+Gr	3PH+Gr
PESO / WEIGHT	kg		954	1010	1035